

ASSEMBLY INSTRUCTIONS

- 1) REMOVE THE INSULATOR ASSEMBLY (929) FROM THE PLUG BODY (933) BY REMOVING THE INSULATOR RETAINING RING (103). THIS IS A SPIRAL TYPE RETAINING RING AND CAN BE REMOVED BY PLACING A SCREWDRIVER UNDER THE END OF THE SPIRAL (A) AND LIFTING THE RING. REMOVE THE ACRYLIC TUBES (117) FROM THE BACK OF THE TEFLON INSULATOR TUBES.
- 2) REMOVE THE INSULATION FROM THE ENDS OF THE CONDUCTORS AS FOLLOWS: PHASE AND GROUND CONDUCTORS 1-7/8" [48mm], GROUND CHECK CONDUCTOR 3/4" (19mm). IN ORDER TO PREVENT THE STRANDS FROM FRAYING, FORM A CAP OVER THE ENDS OF THE CONDUCTOR STRANDING WITH THE COPPER TAPE PROVIDED IN THE KIT. THIS CAN BE DONE BY ROLLING A PIECE OF THE COPPER TAPE AROUND THE STRANDING TO FORM A CYLINDER, LEAVING 1/8" [3mm] TO 3/16" [5mm] OF THE CYLINDER EXTENDING OUT OVER THE STRANDING. FOLD OVER THE END OF THE CYLINDER AND TAP IT DOWN TIGHT TO FORM A THIMBLE-LIKE CAP.
- 3) THE CONTACTS MUST BE REMOVED FOR CONDUCTOR INSTALLATION. THE PHASE CONTACTS (904) ARE REMOVED BY UNSCREWING THE CONTACT NUT (906) USING A TJB PART NO. 992 CONTACT NUT WRENCH (NOT PROVIDED). **DO NOT REMOVE THE TEFLON INSULATOR TUBES FROM THE INSULATOR PLATE.** REMOVE THE GROUND CONTACT (904) AND THE GROUND CHECK CONTACT (905) BY REMOVING THE RETAINING RINGS, (87) FOR THE GROUND AND (911) FOR THE GROUND CHECK, WITH TJB PART NO. 22R PLIERS. BE CAREFUL TO AVOID OVER BENDING THE RETAINING RINGS. INSERT THE CONDUCTORS INTO THE PHASE CONTACTS AND TIGHTEN THE SET SCREWS USING AN ALLEN WRENCH WITHOUT ADDITIONAL LEVERAGE.
- 4) INSERT THE GROUND CHECK LEAD INTO THE GROUND CHECK (905) AND TIGHTEN THE SET SCREW.
- 5) THE TWO GROUND CONTACTS (904) HAVE BEEN ISOLATED FROM THE SHELL OF THE COUPLER. INSTALL THE GROUND LEADS AS DESIRED AND TIGHTEN THE SET SCREWS.
- 6) SLIDE THE SHRINK TUBES (120) AND THE ACRYLIC TUBES (117) OVER THE PHASE CONDUCTORS AND REINSTALL THE CONTACTS INTO THE INSULATOR ASSEMBLY, THEN REPLACE THE CONTACT NUTS (906) AND AND THE RETAINING RINGS (910 AND 911). WHEN INSTALLING THE GROUND CONTACTS, BE CAREFUL TO INSERT THE 1/8" PIN IN THE GROUND CONTACT INTO THE SLOT IN THE INSULATOR PLATE (D).
- 7) SLIDE THE SHRINK TUBE ALL THE WAY OVER THE PHASE CONTACTS AND AGAINST THE INSULATOR TUBE. APPLY HEAT AT THE INSULATOR TUBE END WORKING BACK TOWARD THE CONDUCTOR. REPLACE THE ACRYLIC TUBES (117) ON THE TEFLON INSULATOR TUBES.
- 8) INSTALL THE INSULATOR O-RING INTO THE GROOVE IN THE O.D. OF THE INSULATOR PLATE AND APPLY A SMALL AMOUNT OF SILICONE GREASE (PROVIDED) TO THE O-RING TO EASE INSERTION OF THE INSULATOR INTO THE PLUG BODY. INSTALL THE INSULATOR. TAKE CARE TO ALIGN THE TWO LOCATING TABS (B) ON THE INSULATOR WITH THE NOTCHES PROVIDED IN THE PLUG BODY. REPLACE THE INSULATOR RETAINING RING.

ITEM#	QTY.	PART NO.	DESCRIPTION
XX	1	342	COPPER SHIELDING TAPE (NOT SHOWN)
82	1	184-40	NYLON BALL BEARING - SET OF 40
83	1	151	DUST SEAL
84	10	314-	BRONZE SET SCREW (SPECIFY SIZE)
87	2	942M	GROUND CONTACT RETAINING RING
100	2	181	1/4-20 x 5/8 HHCS
101	1	171	COVER CABLE ASSEMBLY
103	1	327	INSULATOR RETAINING RING
106	4	185J	N/T PIN
107	1	315	1/4-20 x 3/8 SET SCREW
117	3	417	ACRYLIC COMPOUNDING TUBE
120	3	428	HEAT SHRINK TUBE
130	6	940	LOCK WASHER
166	6	424	3/8-16 x 1-1/4 SHCS
901	1	964B-COMP	LVNT PLUG NUT - 3KV- 4 SLOT
903	3	972-COMP	MALE PHASE CONTACT ASSEMBLY
904	2	973A-COMP	MALE GROUND CONTACT ASSEMBLY
905	1	974A-COMP	MALE GROUND CHECK CONTACT ASSEMBLY
906	3	978-COMP	MALE PHASE CONTACT NUT ASSEMBLY
907	3	984	PHASE CONTACT O-RING
908	1	986	INSULATOR O-RING
909	2	987	MALE GROUND CONTACT O-RING
910	1	988	MALE GROUND CHECK CONTACT O-RING
911	1	989	MALE GROUND CHECK CONTACT RETAINING RING
912	1	926	LVNT PLUG O-RING
923	1	824	LVNT PLUG DUST COVER - 3KV AND 1KV
929	1	971TM3-COMP	MALE INSULATOR ASSEMBLY - 3KV
932	1	981	BALL BEARING ACCESS PLUG
933	1	965PBF	LVNT PLUG BODY

NOTE; ALL HARDWARE IS STAINLESS STEEL UNLESS OTHERWISE SPECIFIED

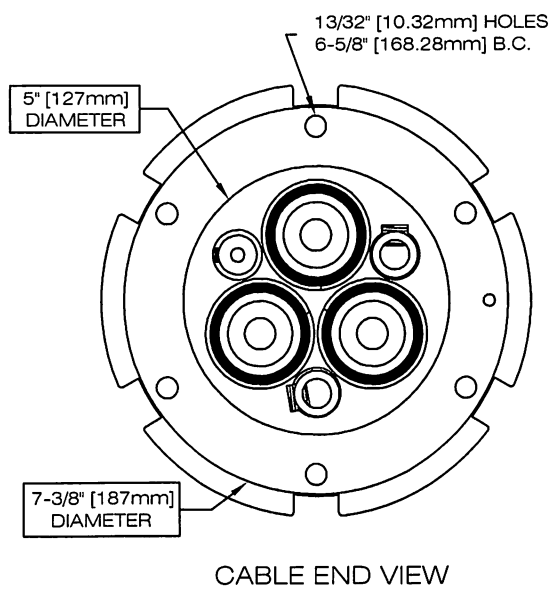

CABLE END VIEW

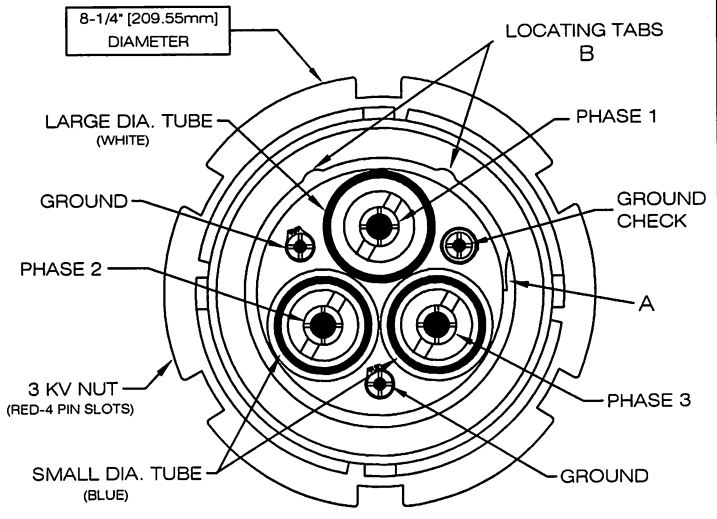

CONTACT END VIEW