

CONTACT END VIEW

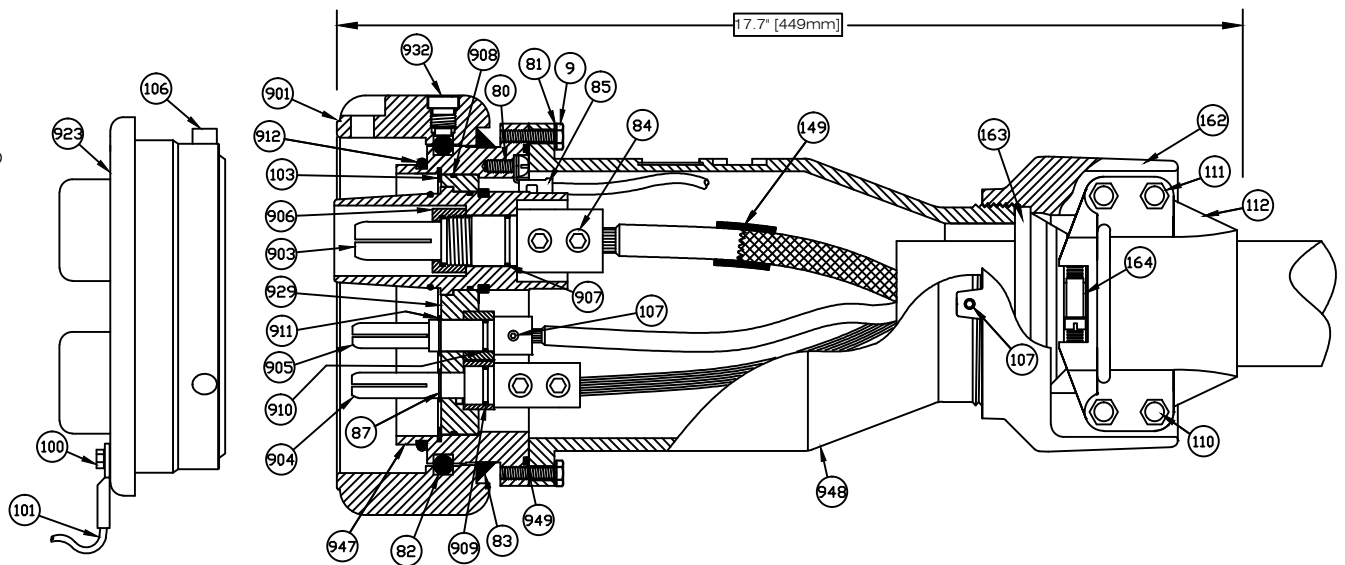

ASSEMBLY INSTRUCTIONS

NOTE:
 IN ORDER TO MEET COMMONWEALTH OF PENNSYLVANIA REQUIREMENTS THERE MUST BE A **SOLDERED** CONNECTION ATTACHING THE SHIELD TO THE GROUND WIRES. WIRE FOR THIS CONNECTION IS PROVIDED IN THE COUPLER KIT.

- 1) REMOVE THE END BELL (948) FROM THE PLUG BODY (947) BY REMOVING THE TWO 1/4" BY 1" BOLTS (9) AND LOCK WASHERS (81). REMOVE THE INSULATOR FROM THE PLUG BODY BY PLACING A SHARP SCREWDRIVER IN THE NOTCH ON THE END OF THE RETAINING RING (103) AND LIFTING IT OUT OF THE GROOVE.
- 2) SLIDE THE FOLLOWING PARTS OVER THE CABLE IN THE FOLLOWING ORDER; END CASTING (162), HOSE CLAMP (164), CABLE SEAL (163), END BELL (948), PLUG BODY O-RING (949) AND THE PLUG BODY (947).
- 3) REMOVE 7-1/2" [190.5mm] OF THE JACKET FROM THE CABLE. **DO NOT CUT INTO THE UNDERLYING CONDUCTORS**. FOLD THE GROUND AND GROUND CHECK WIRES BACK AND OUT OF THE WAY.
- 4) REMOVE 6" [152mm] OF THE SHIELD AND 5-1/2" [140mm] OF THE SEMI-CON FROM THE PHASE CONDUCTORS. COVER THE ENDS OF THE BRAID AND THE SEMI-CON WITH 2 LAYERS OF INSULATING TAPE.
- 5) REMOVE THE INSULATION FROM THE ENDS OF THE CONDUCTORS AS FOLLOWS; PHASE AND GROUND CONDUCTORS 1-7/8" [48mm], GROUND CHECK CONDUCTOR 3/4" (19mm). IN ORDER TO PREVENT THE STRANDS FROM FRAYING, FORM A CAP OVER THE ENDS OF THE CONDUCTOR STRANDING WITH THE COPPER TAPE PROVIDED IN THE KIT. FORM THE CAP BY ROLLING A PIECE OF THE COPPER TAPE AROUND THE STRANDING TO FORM A CYLINDER, LEAVING 1/8" [3mm] TO 3/16" [5mm] OF THE CYLINDER EXTENDING OUT OVER THE STRANDING. FOLD OVER THE END OF THE CYLINDER AND TAP IT DOWN TIGHT TO FORM A THIMBLE-LIKE CAP.
- 6) THE CONTACTS DO NOT HAVE TO BE REMOVED FROM THE INSULATOR TO INSTALL THE CONDUCTORS. INSERT THE CONDUCTORS INTO THE PHASE CONTACTS (903) AND TIGHTEN THE SET SCREWS USING AN ALLEN WRENCH WITHOUT ADDITIONAL LEVERAGE.

- 7) INSERT THE GROUND CHECK LEAD INTO THE GROUND CHECK (905) AND TIGHTEN THE SET SCREW.
- 8) THE TWO GROUND CONTACTS (904) HAVE BEEN ISOLATED FROM THE SHELL OF THE COUPLER. INSTALL THE GROUND LEADS AS DESIRED AND TIGHTEN THE SET SCREWS.
- 9) INSTALL THE O-RING (908) INTO THE GROOVE ON THE O.D. OF THE INSULATOR AND APPLY A SMALL AMOUNT OF THE SILICONE GREASE (PROVIDED) TO THE O-RING . ALIGN THE LOCATING TABS (B) WITH THE INDENTS IN THE PLUG BODY AND INSERT THE INSULATOR ASSEMBLY INTO THE PLUG BODY. INSTALL THE INSULATOR RETAINING RING.
- 10) MAKE SURE THE PLUG BODY O-RING IS PROPERLY SEATED IN THE GROOVE IN THE FACE OF THE PLUG BODY. ALIGN THE ROLL PIN IN THE BELL WITH THE UNTHREADED HOLE IN THE PLUG BODY AND BOLT THE END BELL ONTO THE PLUG BODY USING THE SIX 1/4" X 1" BOLTS AND LOCK WASHERS.
- 11) SEAT THE CABLE SEAL (163) ON THE REAR OF THE END BELL. MAKE CERTAIN THE SET SCREW (107) IS BACKED OUT AND SCREW THE END CASTING (162) ONTO THE END BELL. **HAND TIGHTEN ONLY**. TIGHTEN THE SET SCREW.
- 12) POSITION THE HOSE CLAMP (164) SO THAT THE SCREW IS ACCESSIBLE FROM THE RECESS IN THE CABLE CLAMP (112) AND TIGHTEN THE CLAMP ONTO THE CABLE SEAL.
- 13) CENTER THE CABLE ON THE END CASTING AND POSITION THE CABLE CLAMPS (112) SO THAT THE CABLE IS CENTRALLY POSITIONED AND TIGHTEN THE NUTS (111) AND BOLTS (110).

ITEM#	QTY.	PART#	DESCRIPTION
X	1	721	END BELL ALIGNMENT PIN (NOT SHOWN)
XX	1	489	WIRE WRAP (NOT SHOWN)
XXX	1	342	COPPER SHIELDING TAPE (NOT SHOWN)
9	6	182	1/4-20 X 1 HEX HEAD CAPSCREW
80	1	316	1/4-20 X 1/2 PLATED BRASS SCREW
81	7	202	1/4" LOCK WASHER
82	1	184-40	NYLON BALL BEARING - SET OF 40
83	1	151	DUST SEAL
84	10	314	BRONZE SET SCREW - SPECIFY SIZE
85	1	333	INTERNAL GROUND LEAD ASSEMBLY
87	2	942M	GROUND CONTACT RETAINING RING
100	1	181	1/4-20 x 5/8 HHCS
101	1	171D	COVER CABLE ASSEMBLY
103	1	920	INSULATOR RETAINING RING
106	3	185J	NO THREAD PIN
107	2	315	1/4-20 x 3/8 SET SCREW
110	4	167	3/8-16 x 3 HEX HEAD TAPP BOLT
111	4	168	3/8-16 LOCK NUT
112	2	120A-	CABLE CLAMP - SPECIFY SIZE
149	1	216A	INSULATING TAPE
162	1	939-COMP	END CASTING ASSEMBLY
163	1	123	CABLE SEAL - SPECIFY SIZE
164	1	187	HOSE CLAMP
901	1	964A-COMP	LVNT PLUG NUT - 480V- 3 SLOT
903	3	972-COMP	MALE PHASE CONTACT ASSEMBLY
904	2	973A-COMP	MALE GROUND CONTACT ASSEMBLY
905	1	974A-COMP	MALE GROUND CHECK CONTACT ASSEMBLY
906	3	978-COMP	MALE PHASE CONTACT NUT ASSEMBLY
907	3	984	PHASE CONTACT O-RING
908	1	986	INSULATOR O-RING
909	2	987	MALE GROUND CONTACT O-RING
910	1	988	MALE GROUND CHECK CONTACT O-RING
911	1	989	MALE GROUND CHECK RETAINING RING
912	1	926	COUPLING O-RING
923	1	823	LVNT PLUG DUST COVER - 480V AND 5KV
929	1	971M48-COMP	MALE INSULATOR ASSEMBLY - 480V
932	1	981	BALL BEARING ACCESS PLUG
947	1	825	PLUG BODY
948	1	912	LVNT END BELL
949	1	9101	PLUG BODY O-RING

NOTE: ALL HARDWARE IS STAINLESS STEEL UNLESS OTHERWISE SPECIFIED