

ITEM#	QTY.	PART NO.	DESCRIPTION
XX	1	342	COPPER SHIELDING TAPE (NOT SHOWN)
84	10	314 -	BRONZE SET SCREW
87	2	329	GROUND CONTACT RETAINING RING
100	2	181	1/4-20 x 5/8 HHCS
101	1	171	COVER CABLE ASSEMBLY
103	1	327	INSULATOR RETAINING RING
106	3	185R-COMP	ROLLER PIN AND SLEEVE
107	1	315	1/4-20 x 3/8 SET SCREW
130	6	940	LOCK WASHER
166	6	424	3/8-16 x 1-1/4 SHCS
907	3	984	PHASE CONTACT O-RING
908	1	986	INSULATOR O-RING
909	2	987	GROUND CONTACT O-RING
910	1	988	GROUND CHECK CONTACT O-RING
911	1	989	GROUND CHECK CONTACT RETAINING RING
913	1	971TF48-COMP	FEMALE INSULATOR ASSEMBLY - 480V
914	3	975	FEMALE PHASE CONTACT
915	2	976A	FEMALE GROUND CONTACT
916	1	977A	FEMALE GROUND CHECK CONTACT
917	3	979-COMP	FEMALE PHASE CONTACT NUT ASSEMBLY
918	1	965A-COMP	LVNT SOCKET FLANGE ASSEMBLY - 480V
919	1	980S3	LVNT SOCKET COVER - 480V-5KV
921	1	993	FEMALE GROUND CONTACT ISOLATION BUSHING
934	1	980S.1	LVNT SOCKET COVER WAVE SPRING
935	1	194	1/4-20 LOCK NUT

NOTE: ALL HARDWARE IS STAINLESS STEEL UNLESS OTHERWISE SPECIFIED

ASSEMBLY INSTRUCTIONS

- 1) REMOVE THE INSULATOR ASSEMBLY (913) FROM THE SOCKET FLANGE (918) BY REMOVING THE INSULATOR RETAINING RING (103). THIS IS A SPIRAL TYPE RETAINING RING AND CAN BE REMOVED BY PLACING A SCREWDRIVER UNDER THE END OF THE SPIRAL (A) AND LIFTING THE RING.
- 2) REMOVE THE INSULATOR FROM THE SOCKET FLANGE BY LAYING THE FRONT OF THE INSULATOR TUBES (CONTACT SIDE) ON A CLEAN FLAT SURFACE AND PRESSING ON THE SOCKET FLANGE.
- 3) REMOVE THE INSULATION FROM THE ENDS OF THE CONDUCTORS AS FOLLOWS: PHASE AND GROUND CONTACTS 1-7/8" [48mm], GROUND CHECK CONTACT 3/4" (19mm). IN ORDER TO PREVENT THE STRANDS FROM FRAYING, FORM A CAP OVER THE ENDS OF THE CONDUCTOR STRANDING WITH THE COPPER TAPE PROVIDED IN THE KIT. FORM THE CAP BY ROLLING A PIECE OF THE COPPER TAPE AROUND THE STRANDING TO SHAPE A CYLINDER, LEAVING 1/8" (3mm) TO 3/16" (5mm) OF THE CYLINDER EXTENDING OUT OVER THE STRANDING. FOLD OVER THE END OF THE CYLINDER AND TAP IT DOWN TO FORM A THIMBLE LIKE CAP.
- 4) SLIDE THE INSULATOR RETAINING RING BACK OVER THE CONDUCTORS BEFORE ATTACHING THE CONTACTS.
- 5) THE CONTACTS DO NOT HAVE TO BE REMOVED FROM THE INSULATOR TO INSTALL THE CONDUCTORS. INSERT THE CONDUCTORS INTO THE PHASE CONTACTS AND TIGHTEN THE SET SCREWS USING AN ALLEN WRENCH WITHOUT ADDITIONAL LEVERAGE.
- 6) INSERT THE GROUND CHECK LEAD INTO THE GROUND CHECK CONTACT (916) AND TIGHTEN THE SET SCREW.
- 7) THE TWO GROUND CONTACTS (915) HAVE BEEN ISOLATED FROM THE SHELL OF THE COUPLER. INSTALL THE GROUND LEADS AS DESIRED AND TIGHTEN THE SET SCREWS.
- 8) APPLY A SMALL AMOUNT OF SILICONE GREASE (PROVIDED) TO THE O-RING TO EASE INSERTION OF THE INSULATOR INTO THE SOCKET FLANGE. MAKE CERTAIN THE GROUND ISOLATION BUSHING (921) IS ON THE GROUND CONTACT IN THE 6 O-CLOCK POSITION OF THE INSULATOR. INSTALL THE INSULATOR AND REPLACE THE INSULATOR RETAINING RING. **MAKE CERTAIN THAT THE RETAINING RING IS COMPLETELY SEATED IN THE GROOVE.**

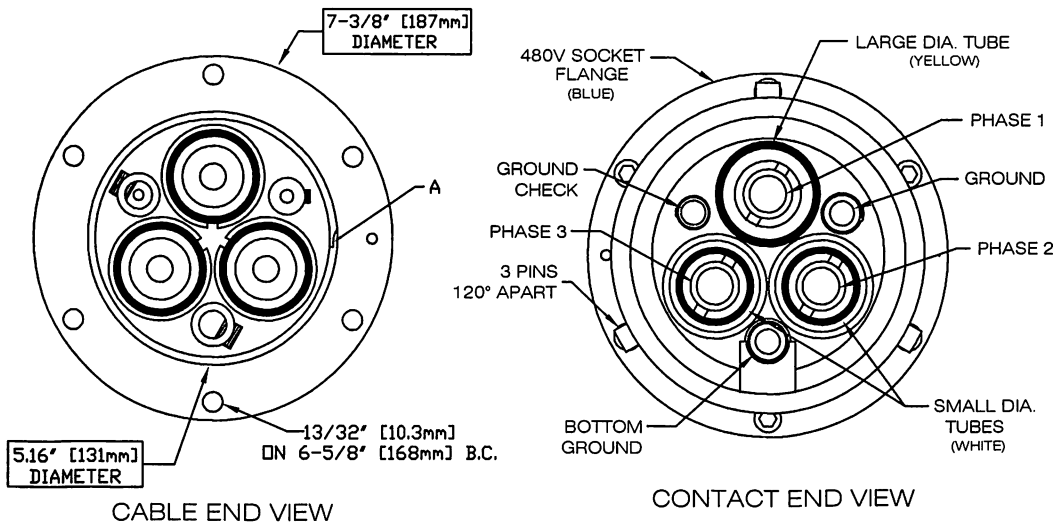

TJB INC

CATALOG NO. - SFG48B (12-27-10)

TJB INC